

*a stylish "drop-in" server system
that will suit any budget*

PRO-efficient



CHILLED FAN BLOWN DECK DISPLAY

the PRO-ficient CHILLED FAN BLOWN DECK DISPLAY

The PRO-ficient Chilled Fan Blown Deck represents the very best in modular design and functionality and is used as a "drop in" unit to extend any servery layout you care to design. It can be fitted to any new or existing counter base or shopfitted unit and will add a touch of quality and style to any servery system.

Our stylish PRO-ficient units are completely self contained and designed to complement each other perfectly. When used in combination with other PRO-ficient units or as simple stand alone display, they can be relied on to perform well for many years with the minimum of maintenance.

Available in a range of sizes and finishes with many optional extras to extend functionality, the comprehensive PRO-ficient range includes: chilled and heated displays, chilled multi-decks, chilled fan blown decks and wells, chilled and heated deli units, heated bain marie units, heated ceramic hotplates, condiment and soup units.

These units comply in every respect with current CE and Food Hygiene regulations.

While all PRO-ficient units perform well and have been designed to meet client demands, PROMART recommends that a Bespoke Counter is still the best option in terms of longevity and aesthetics. PROMART reserves the right to modify designs and specifications at any time without notice.

Ideal for the display of salads and chilled plated meals, this unit allows food to be maintained at chilled temperatures in the refrigerated well while the additional shelf enables effective display at ambient temperatures. The unique design allows the recessed deck to be raised by a centrally positioned hinge mechanism in order to facilitate easy maintenance and cleaning.

The wells are covered by removable stainless steel trivet plates, which are also available in a wider range of material (Granite, Corian etc).

The well is chilled by a robust condenser unit which is located within a suitably sized under-slung carriage. Condensate is dealt with efficiently by an integral evaporation unit.

The Chilled Fan Blown Well is provided with an electrical control box which can be located anywhere within 1000 mm of the unit.

The optional full height glass front screen may be hinged forward in order to facilitate easy maintenance and cleaning.

Available in a comprehensive range of multiple gastronorm size increments.

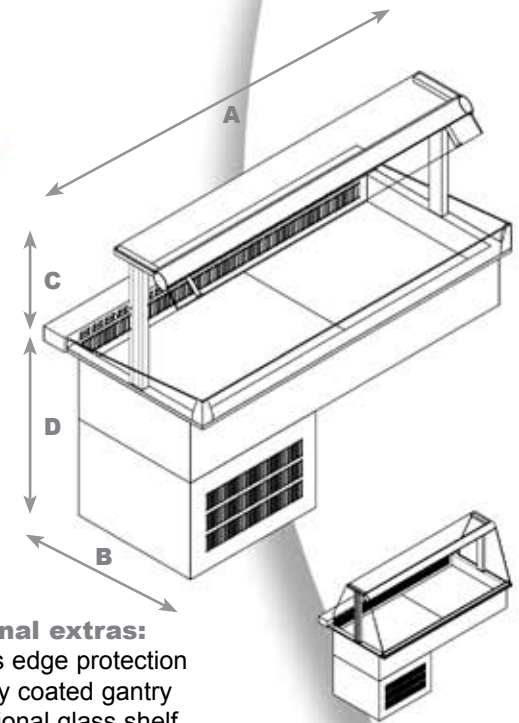

FULL HEIGHT GLASS SCREENS TO FRONT AND ENDS

Optional extras:

- Glass edge protection
- Epoxy coated gantry
- Additional glass shelf
- Multi-functional digital controller
- Remote compressor unit
- Granite trivets
- Polyethylene cutting board
- Tray Slide

CHILLED FAN BLOWN DECK DISPLAY

Part N ^o	Capacity GN	Dim A mm	Dim B mm	Dim C mm	Dim D mm	Weight kg	Power	Wattage
PF-FBD-2	2 x 1/1	790	745	540	670	130 kg	13 amp / 230 v	2000
PF-FBD-3	3 x 1/1	1134	745	540	670	160 kg	13 amp / 230 v	2200
PF-FBD-4	4 x 1/1	1478	745	540	670	200 kg	13 amp / 230 v	2300
PF-FBD-5	5 x 1/1	1822	745	540	670	230 kg	13 amp / 230 v	2400
PF-FBD-6	6 x 1/1	2166	745	540	670	280 kg	13 amp / 230 v	2500

