

a stylish "drop-in" server system  
that will suit any budget!

# PRO-ficient



## HEATED CERAMIC HOTPLATE DISPLAY

# the PRO-ficient HEATED CERAMIC HOTPLATE DISPLAY

The PRO-ficient Heated Ceramic Hotplate servery counter represents the very best in modular design and functionality and is used as a "drop in" unit to extend any servery layout you care to design. It can be fitted to any new or existing counter base or shopfitted unit and will add a touch of quality and style to any servery system.

Our stylish PRO-ficient units are completely self contained and designed to complement each other perfectly. When used in combination with other PRO-ficient units or as simple stand alone display, they can be relied on to perform well for many years with the minimum of maintenance.

Available in a range of sizes and finishes with many optional extras to extend functionality, the comprehensive PRO-ficient range includes: chilled and heated displays, chilled multi-decks, chilled fan blown decks and wells, chilled and heated deli units, heated bain marie units, heated ceramic hotplates, condiment and soup units.

These units comply in every respect with current CE and Food Hygiene regulations.

While all PRO-ficient units perform well and have been designed to meet client demands, PROMART recommends that a Bespoke Counter is still the best option in terms of longevity and aesthetics. PROMART reserves the right to modify designs and specifications at any time without notice.

Our self help or assisted service hotplates are available in configurations ranging from a double to a six hotplate module with a choice of overall or individual hotplate control.

The unit is also amply heated from above by steplessly variable 300 watt infra-red quartz halogen lights ensuring clean, attractive display of merchandise.

The full height glass front screen is hinged forward in order to facilitate easy maintenance and cleaning.

Each hotplate equates to gastronorm 1/1. Available in a comprehensive range of multiple gastronorm size increments.

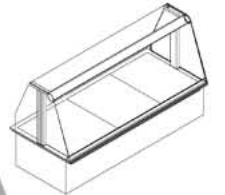
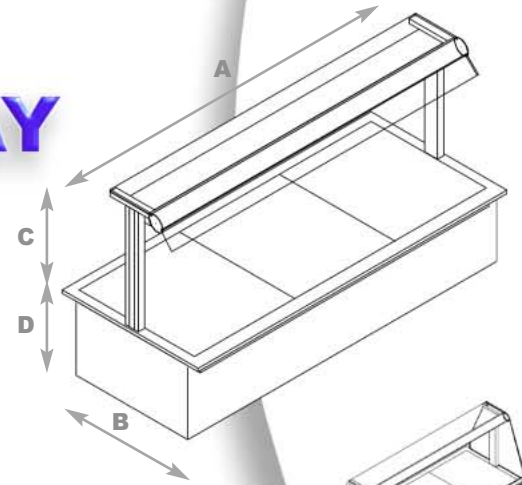

FULL HEIGHT GLASS SCREENS TO FRONT AND ENDS

#### Optional extras:

- Glass edge protection
- Colour epoxy coated gantry
- Multi-functional digital controller
- Individual control per hotplate
- Tray Slide
- End Glass

#### HEATED CERAMIC HOTPLATE - No waste fittings are required with these units

Part N°	Capacity GN	Dim A mm	Dim B mm	Dim C mm	Dim D mm	Cut Out mm	Weight kg	Power	Wattage
PF-HCH-2	2 x 1/1	790	650	540	46	770 x 610	30 kg	13 amp / 230 v	2000
PF-HCH-3	3 x 1/1	1134	650	540	46	1114 x 610	40 kg	13 amp / 230 v	2200
PF-HCH-4	4 x 1/1	1478	650	540	46	1458 x 610	50 kg	13 amp / 230 v	2300
PF-HCH-5	5 x 1/1	1822	650	540	46	1802 x 610	60 kg	13 amp / 230 v	2400
PF-HCH-6	6 x 1/1	2166	650	540	46	2146 x 610	70 kg	13 amp / 230 v	2500